

IMPORTANT INSTALLATION NOTES:

- FIXTURE TO BE INSTALLED IN ACCORDANCE WITH ALL APPLICABLE CODES BY A QUALIFIED ELECTRICIAN OR OTHER PERSON FAMILIAR WITH THE CONSTRUCTION AND OPERATION OF THIS PRODUCT AND THE HAZARDS INVOLVED.
- FIXTURE(S) MUST BE INSTALLED PRIOR TO CEILING.
- INSURE ALL HANGING POINTS ARE IN LINE WITH THE CENTERLINE OF THE FIXTURE RUN. IF THEY ARE NOT PROPERLY ALIGNED, THE RUN WILL NOT HANG STRAIGHT.
- HANG INDIVIDUAL OR START FIXTURE SECTIONS FIRST. THESE WILL USE (4) THREADED RODS AND BE SELF SUPPORTING. TAKE CARE TO LEVEL THE FIXTURE AT THIS POINT, ESPECIALLY FOR CONTINUOUS RUNS.
- FOR CONTINUOUS RUNS, HANG EACH SUCCESSIVE SECTION USING (1) ADDITIONAL INSTALLED THREADED ROD AT PRE-DETERMINED LOCATION AND THE JOINING AND ALIGNING HARDWARE PROVIDED WITH THE FIXTURES, AND LEVEL EACH SECTION WITH THE PREVIOUS ONE.
- ***DO NOT ATTEMPT TO BOLT FIXTURES TOGETHER AND RAISE THE ASSEMBLED RUN AT ONE TIME. THIS WILL DAMAGE THE BRACKETRY AND PREVENT THE FIXTURES FROM JOINING TIGHTLY, AND WILL VOID THE FIXTURE WARRANTY!*****
- FOLLOW THE SAME PROCEDURE ABOVE TO INSTALL THE END UNIT.
- RECHECK ALL FIXTURES FOR LEVEL AND INSURE ALL JOINTS ARE TIGHT.
- IF SMALL GAPS OCCUR BETWEEN FIXTURE SECTIONS, APPLY A SMALL AMOUNT OF CAULK BETWEEN SECTIONS AND WIPE OFF EXCESS WITH A DAMP CLOTH.

Project:		MLS3	
		TRIMLESS/DRYWALL INSTALLATION INSTRUCTION	
Distributor:	Type:		
By:	Date:	Scale:	
Dwg. no.:	Rev.:	Size:	

MERCURY
ARCHITECTURAL
LIGHTING

20 Audrey Place Fairfield, NJ 07004 U.S.A.

CATALOG NO:
MLS3G3-N5-48-500-35K-HTA-1%-U

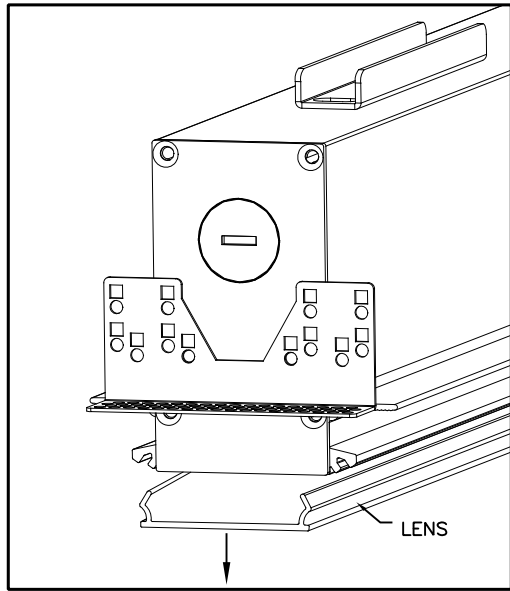

STEP 1:
-MARK EACH LENS TO CORRESPONDING FIXTURE AND PUT ASIDE TO BE REINSTALLED IN STEP 10.
*NOTE- FIXTURE AND LENS SHIPPED IN SAME BOX BUT UNINSTALLED.

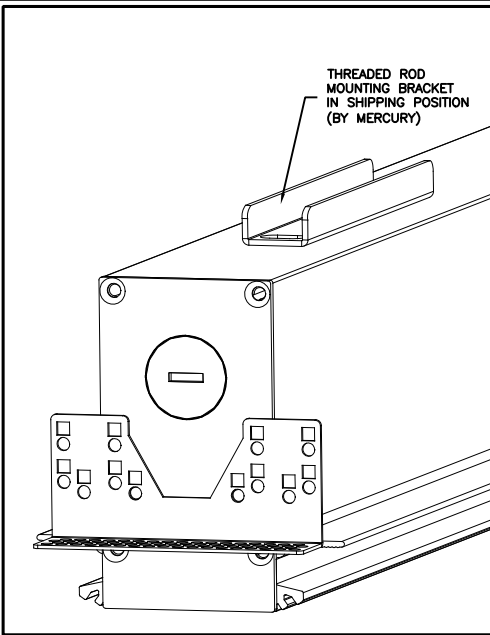

STEP 2:
-PREPARE FIXTURE FOR INSTALLATION BY ROTATING THE THREADED ROD MOUNTING BRACKET 90 DEGREES

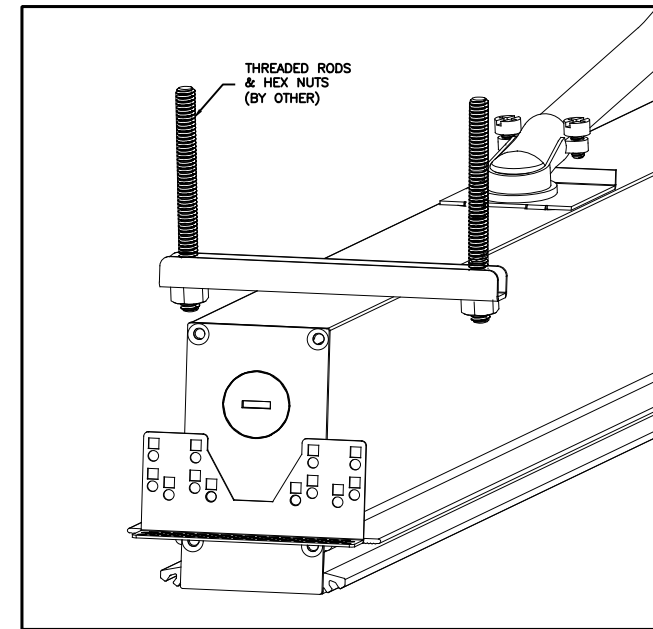
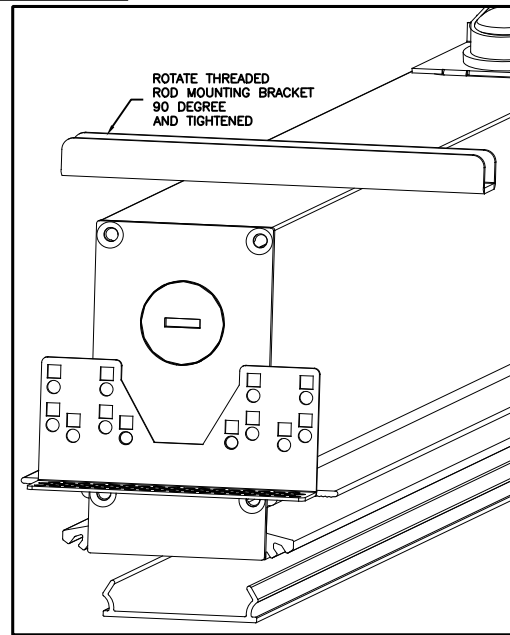

STEP 3:
-SECURE 1/4-20 THREADED RODS TO MOUNTING BRACKET WITH HEX NUTS.
-SECURE FIXTURE TO STRUCTURE ABOVE.
-CONTINUE TO STEP 4 & 5 FOR CONNECTING MORE THAN MIDDLE AND END.
-GO TO STEP 6 FOR 'INDIVIDUAL' MODULE

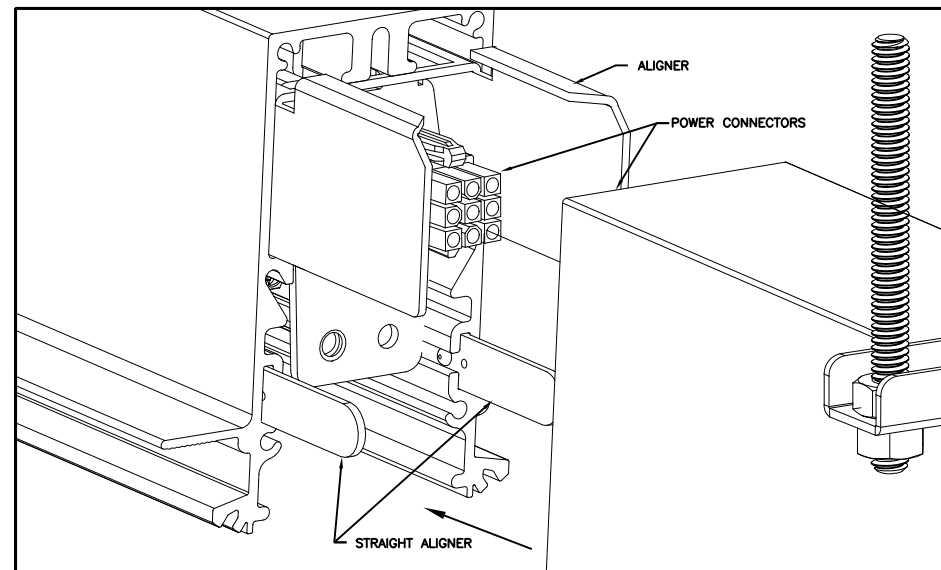

STEP 4
-ALIGN FIXTURE USING ALIGNERS BY MERCURY
-CONNECT POWER CONNECTORS BETWEEN FIXTURES

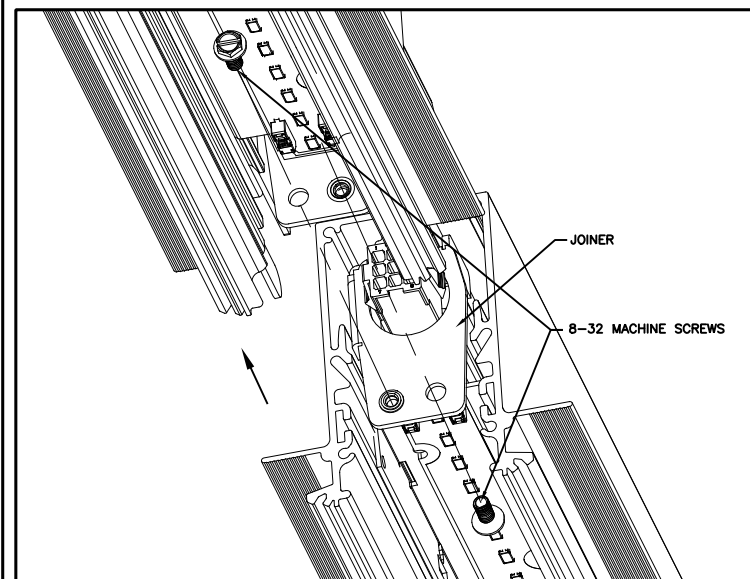

STEP 5
-PUSH EXCESS POWER CONNECTOR CABLE BACK INTO FIXTURE THROUGH JOINERS AS SHOWN FOR MLS-2 OR TO EITHER SIDE OF JOINER FOR MLS-3
-SECURE FIXTURES TOGETHER USING 8-32 SCREWS ON JOINER (PROVIDED BY MERCURY).
-REPEAT STEP 2 & 4 AS NEEDED UNTIL THE 'END' MODULE IS INSTALLED

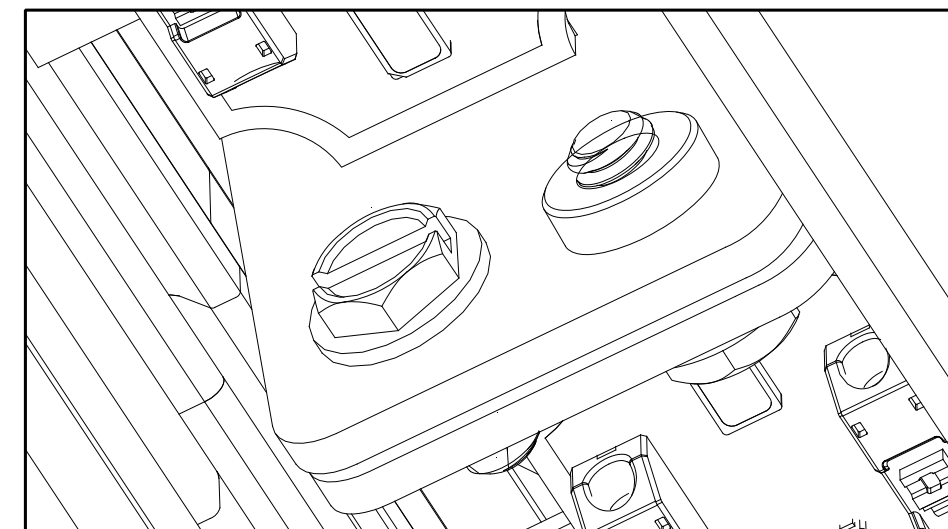

COMPLETE JOINT ASSEMBLY

This document contains confidential and proprietary information and cannot be reproduced or divulged, in whole or part, without authorization in writing by Mercury Architectural Lighting.

Project: MLS3 TRIMLESS/DRYWALL INSTALLATION INSTRUCTION		
Distributor:	Type:	
By:	Date:	Scale:
Dwg. no.:	Rev.	Size:

MERCURY ARCHITECTURAL LIGHTING

20 Audrey Place Fairfield, NJ 07004 U.S.A.

CATALOG NO:
MLS3G3-N5-48-500-35K-HTA-1%-U

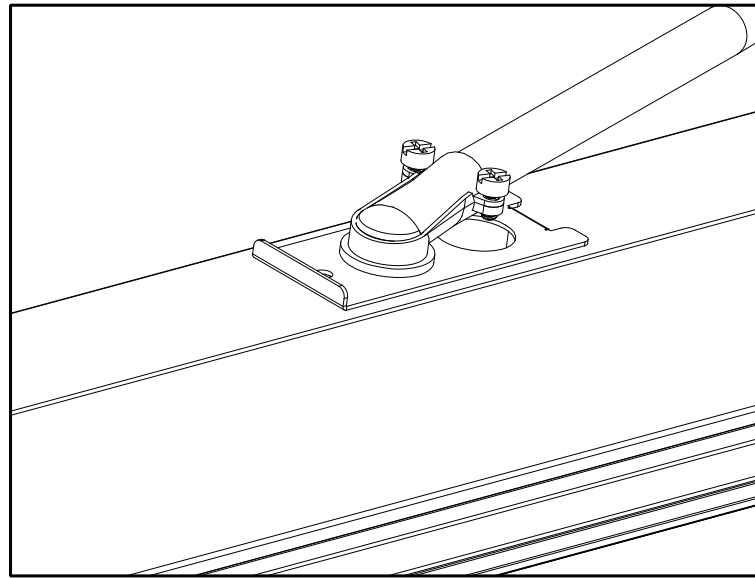
STEP 6
-MAKE ELECTRICAL CONNECTION TO BUILDING SUPPLY.

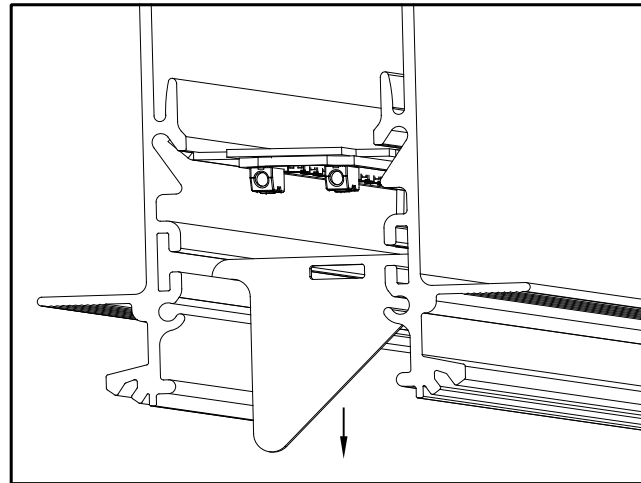

STEP 7
-MAKE SURE BRACKET IS DOWNWARD 90 DEGREES UNTIL FLAT SIDE OF BRACKET IS PERPENDICULAR TO CEILING.
(SHIPPED INSIDE THE FIXTURE)

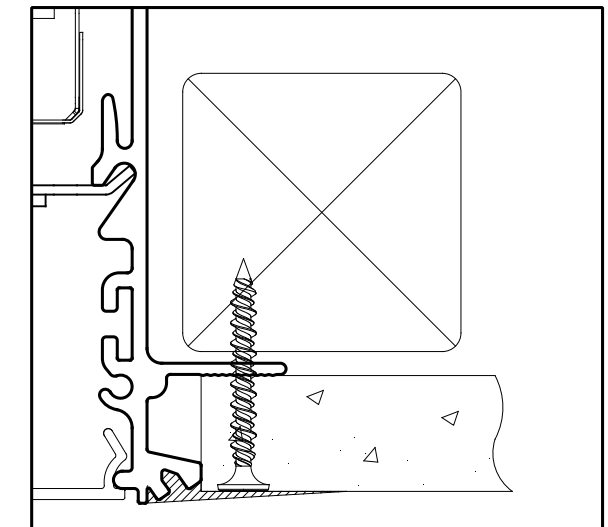

STEP 8
-INSTALL DRYWALL AROUND FIXTURE WITH DRYWALL SCREWS
-MUD AND BLEND EDGES

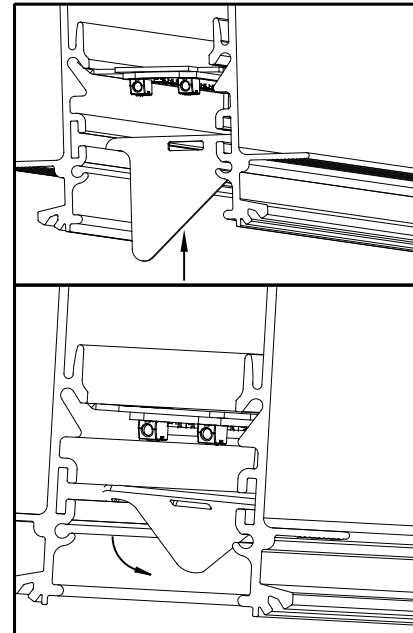

9A

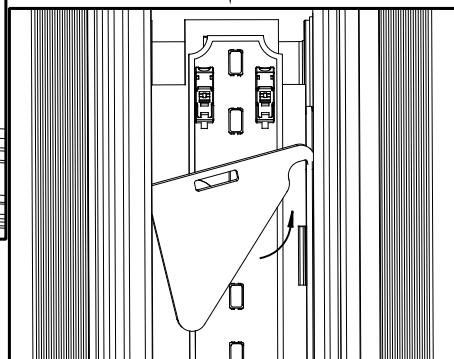
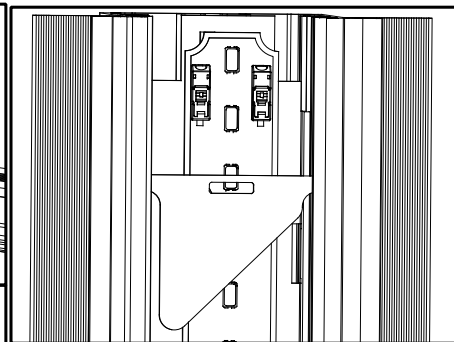

9B

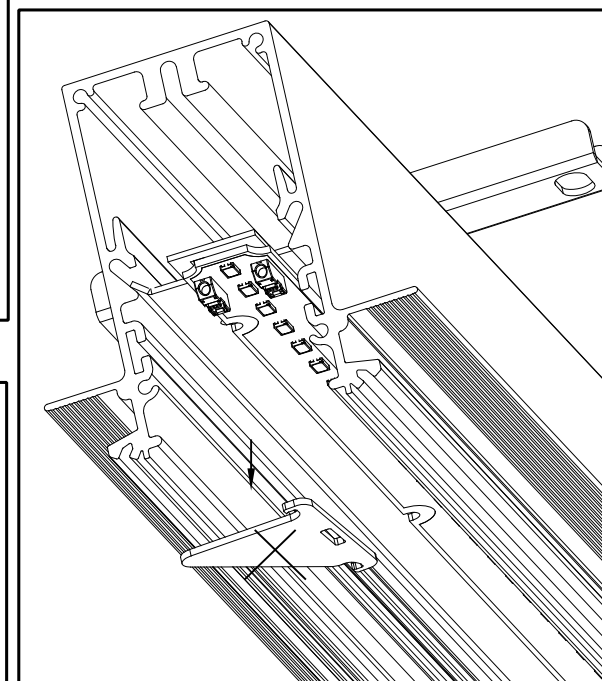

9C

STEP 9--REMOVE TEMP BRACKET AFTER PUTTING UP DRYWALL

STEP 9A--FLIP BRACKET UPWARD 90 DEGREES UNTIL FLAT SIDE OF BRACKET IS PERPENDICULAR TO CEILING.

STEP 9B--USING A FLAT HEAD SCREWDRIVER, ROTATE BRACKET COUNTERCLOCKWISE 90 DEGREES

STEP 9C--DISENGAGE BRACKET FROM GROOVE IN HOUSING. DISCARD BRACKETS AS SHOWN

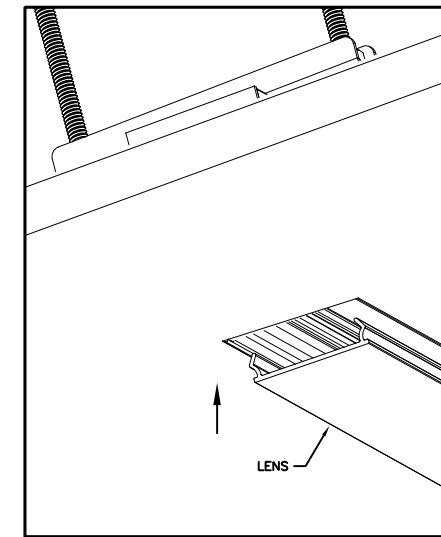

STEP 10
-REINSTALL LENSES IN SAME FIXTURES AS THEY WERE REMOVED FROM STEP 1.

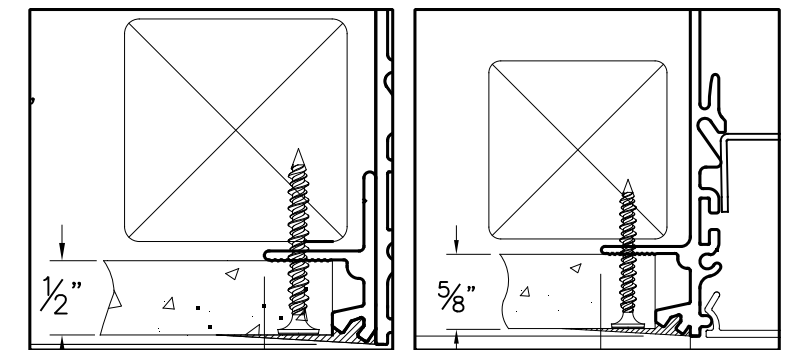

1/2" SHEETROCK

5/8" SHEETROCK

CEILING OPTIONS

This document contains confidential and proprietary information and cannot not be reproduced or divulged, in whole or part, without authorization in writing by Mercury Architectural Lighting.